

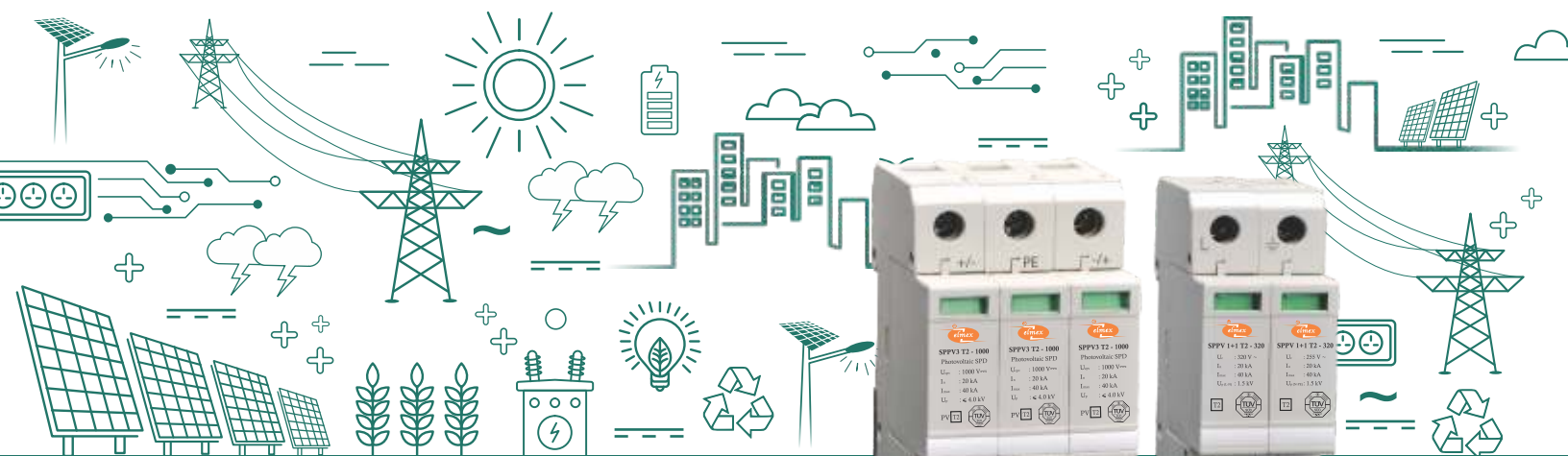

since 1963

Converging
Innovations  Expanding
Solutions



AC & DC
Surge Protection Devices

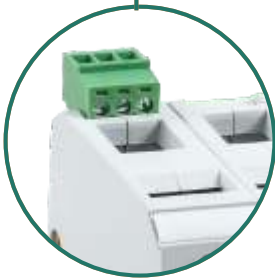

Remote Signaling Contact
To monitor the status of SPD remotely



Pluggable Design
To isolate the plug in case of maintenance



Visual Status Indication
In case of failure, flag switches to red-replacement recommended

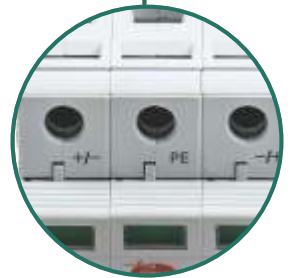

Connectors
Indication of polarities ensuring physical separation between terminals

Features

Type 2 Surge Protection Device

Maximum Discharge Current (8/20µs): 40kA

Pluggable Design - Easy to Replace

Remote Signalling Contact (optional)

Quick Response Time ≤ 25 ns

IEC 61643 - 11 Compliance - for AC SPD

Visual Status - Fault Indication by Red Flag

IEC 61643 - 31 Compliance - for DC SPD



Surge Protective Device (SPD) Terminology



Surge Protective Device (SPD) is designed to limit transient over voltages of atmospheric origin and divert current waves to earth, so as to limit the amplitude of this over voltage to a value that is not hazardous for the electrical installation and electric switchgear.

Type 2 SPD: The type 2 SPD is the main protection system for all low voltage electrical installations. Installed in each electrical switchboard, it prevents the spread of over voltages in the electrical installations and protects the load.

- **Nominal Voltage (Un):** The nominal voltage stands for the nominal voltage of the system to be protected.
- **Maximum Continuous Operating Voltage (Uc):** The maximum continuous operating voltage is the r.m.s value of the maximum voltage which may be connected to corresponding terminals of Surge Protective Device during operations.
- **Maximum Continuous Operating Voltage for PV System (Ucpv):** The maximum continuous operating voltage for Photovoltaic (PV) system is the value of maximum DC voltage which may be permanently applied to terminals of SPD.
- **Voltage Protection Level (Up):** The Voltage Protection Level is the maximum instantaneous value of the voltage at terminals of SPD.
- **Nominal Discharge Current (In):** The nominal discharge current is the peak value of the current that can be passed through SPD having a wave shape of 8/20 μ s.
- **Maximum Discharge Current (Imax):** The maximum discharge current is the peak value of the current which the device can safely discharge through the SPD having a wave shape of 8/20 μ s.



Applications

- Photovoltaic & Wind
- Industry & Automation
- Commercial & Residential Installations
- Telecom, IT & Data Centers
- LED Outdoor & Lighting
- Smart Grid & LV Metering
- Water Treatment



SPD Code Description

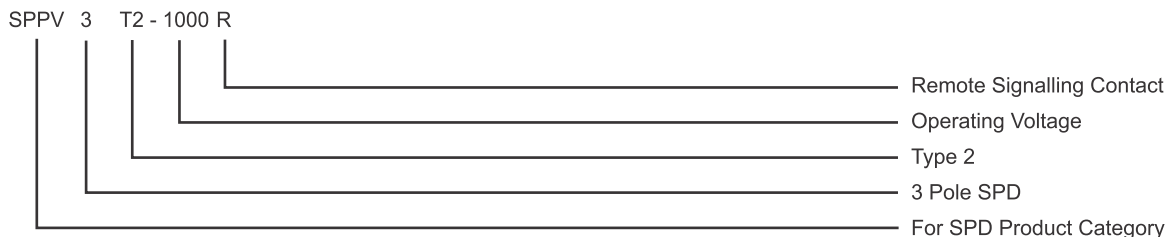



SPPV3+1T2-320

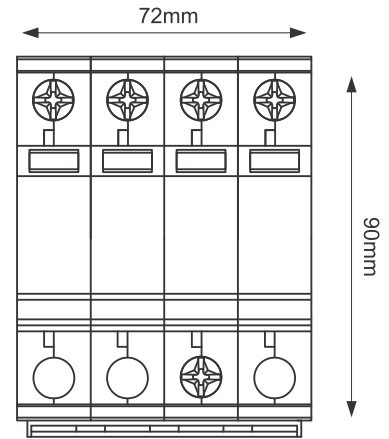

Product Dimension

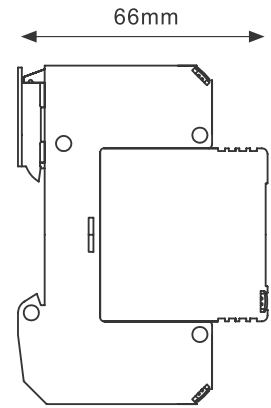

Product Dimension

TECHNICAL PARAMETERS	SPECIFICATIONS
SPD Classification According to EN61643-11	Type 2
SPD Classification According to IEC61643-11	Class II
Nominal Voltage (Un)	230 / 415 V AC
Max. Continuous Operating Voltage (Uc)	320V AC
Max. Continuous Operating Voltage [N-PE] (Uc)	255V AC
Nominal Discharge Current (In)	20kA
Max. Discharge Current (Imax)	40kA
Voltage Protection Level (Up)	≤ 1.5kV
Voltage Protection Level [N-PE] (Up)	≤ 1.5kV
Response Time (tA)	≤ 25ns
Response Time [N-PE] (tA)	≤ 100ns
Operating Temperature Range (Tu)	-40°C to +70°C
Operating State / Fault Indication	Green / Red
Cross-Section Area (Min)	4mm ²
Cross-Section Area (Max)	35mm ²
Mounting	35mm Din rail
Enclosure Material	Thermoplastic UL94-V0
Degree of Protection	IP20

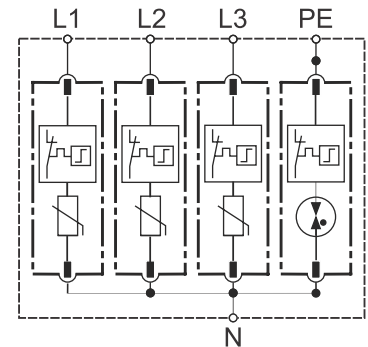

Connection Diagram



SPPV1+1T2-320

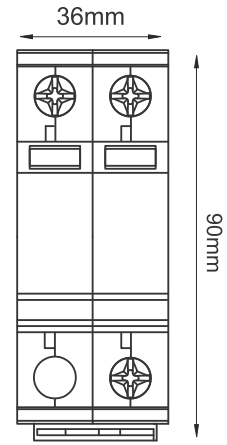

Product Dimension

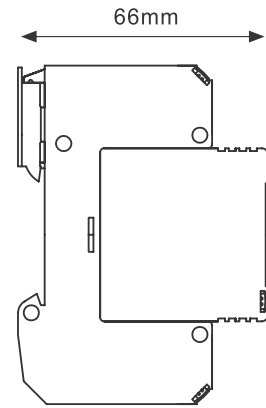

Product Dimension

TECHNICAL PARAMETERS	SPECIFICATIONS
SPD Classification According to EN61643-11	Type 2
SPD Classification According to IEC61643-11	Class II
Nominal Voltage (Un)	230 / 415 V AC
Max. Continuous Operating Voltage (Uc)	320V AC
Max. Continuous Operating Voltage [N-PE] (Uc)	255V AC
Nominal Discharge Current (In)	20kA
Max. Discharge Current (Imax)	40kA
Voltage Protection Level (Up)	≤ 1.5kV
Voltage Protection Level [N-PE] (Up)	≤ 1.5kV
Response Time (ta)	≤ 25ns
Response Time [N-PE] (ta)	≤ 100ns
Operating Temperature Range (Tu)	-40°C to +70°C
Operating State / Fault Indication	Green / Red
Cross-Section Area (Min)	4mm ²
Cross-Section Area (Max)	35mm ²
Mounting	35mm Din rail
Enclosure Material	Thermoplastic UL94-V0
Degree of Protection	IP20

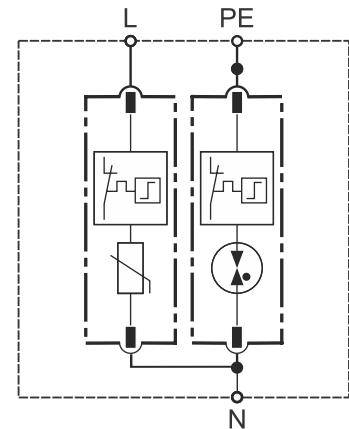

Connection Diagram



SPPV1T2-320

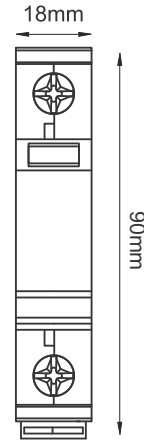

Product Dimension

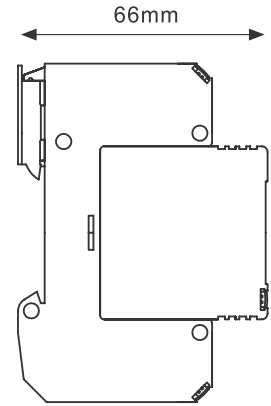

Product Dimension

TECHNICAL PARAMETERS	SPECIFICATIONS
SPD Classification According to EN61643-11	Type 2
SPD Classification According to IEC61643-11	Class II
Nominal Voltage (U _n)	230 / 415 V AC
Max. Continuous Operating Voltage (U _c)	320V AC
Nominal Discharge Current (I _n)	20kA
Max. Discharge Current (I _{max})	40kA
Voltage Protection Level (U _p)	≤ 1.5kV
Response Time (t _Δ)	≤ 25ns
Operating Temperature Range (T _u)	-40°C to +70°C
Operating State / Fault Indication	Green / Red
Cross-Section Area (Min)	4mm ²
Cross-Section Area (Max)	35mm ²
Mounting	35mm Din rail
Enclosure Material	Thermoplastic UL94-V0
Degree of Protection	IP20

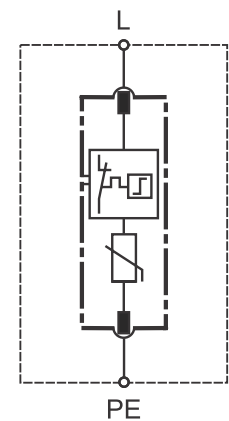

Connection Diagram



SPPV2T2-320

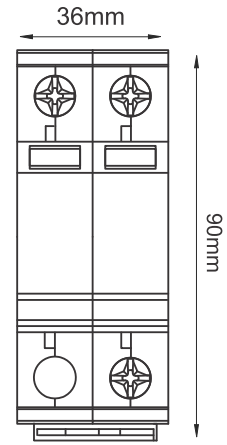

Product Dimension

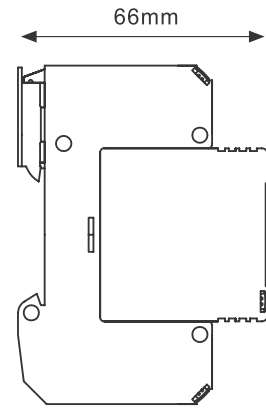

Product Dimension

TECHNICAL PARAMETERS	SPECIFICATIONS
SPD Classification According to EN61643-11	Type 2
SPD Classification According to IEC61643-11	Class II
Nominal Voltage (Un)	230 / 415 V AC
Max. Continuous Operating Voltage (Uc)	320V AC
Nominal Discharge Current (In)	20kA
Max. Discharge Current (Imax)	40kA
Voltage Protection Level (Up)	≤ 1.5kV
Response Time (ta)	≤ 25ns
Operating Temperature Range (Tu)	-40°C to +70°C
Operating State / Fault Indication	Green / Red
Cross-Section Area (Min)	4mm ²
Cross-Section Area (Max)	35mm ²
Mounting	35mm Din rail
Enclosure Material	Thermoplastic UL94-V0
Degree of Protection	IP20

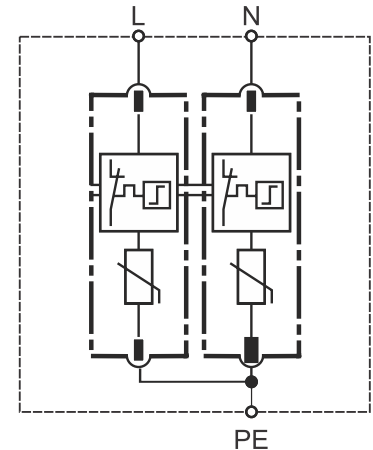

Connection Diagram



SPPV3T2-320

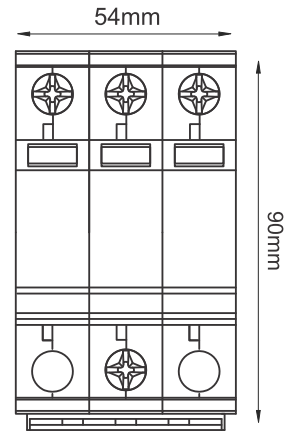

Product Dimension

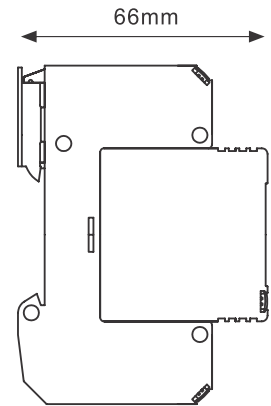

Product Dimension

TECHNICAL PARAMETERS	SPECIFICATIONS
SPD Classification According to EN61643-11	Type 2
SPD Classification According to IEC61643-11	Class II
Nominal Voltage (Un)	230 / 415 V AC
Max. Continuous Operating Voltage (Uc)	320V AC
Nominal Discharge Current (In)	20kA
Max. Discharge Current (Imax)	40kA
Voltage Protection Level (Up)	≤ 1.5kV
Response Time (ta)	≤ 25ns
Operating Temperature Range (Tu)	-40°C to +70°C
Operating State / Fault Indication	Green / Red
Cross-Section Area (Min)	4mm ²
Cross-Section Area (Max)	35mm ²
Mounting	35mm Din rail
Enclosure Material	Thermoplastic UL94-V0
Degree of Protection	IP20

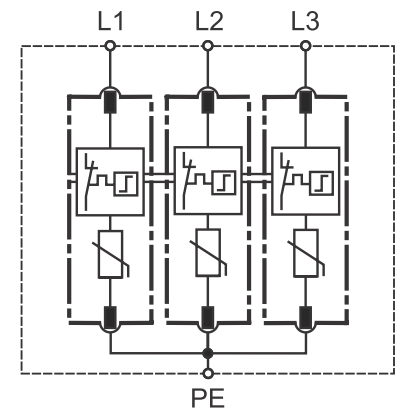

Connection Diagram



SPPV4T2-320

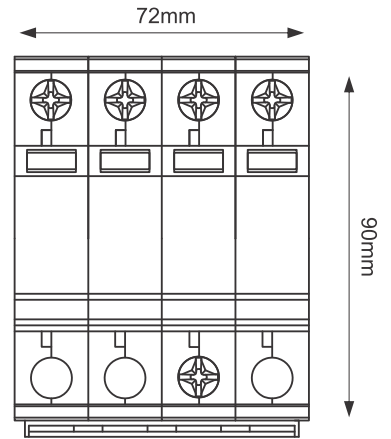

Product Dimension

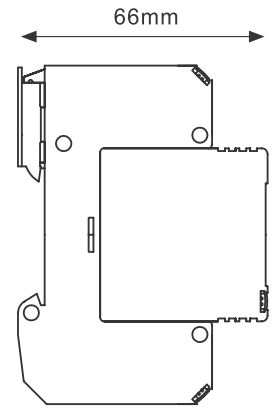

Product Dimension

TECHNICAL PARAMETERS	SPECIFICATIONS
SPD Classification According to EN61643-11	Type 2
SPD Classification According to IEC61643-11	Class II
Nominal Voltage (Un)	230 / 415 V AC
Max. Continuous Operating Voltage (Uc)	320V AC
Nominal Discharge Current (In)	20kA
Max. Discharge Current (Imax)	40kA
Voltage Protection Level (Up)	≤ 1.5kV
Response Time (ta)	≤ 25ns
Operating Temperature Range (Tu)	-40°C to +70°C
Operating State / Fault Indication	Green / Red
Cross-Section Area (Min)	4mm ²
Cross-Section Area (Max)	35mm ²
Mounting	35mm Din rail
Enclosure Material	Thermoplastic UL94-V0
Degree of Protection	IP20

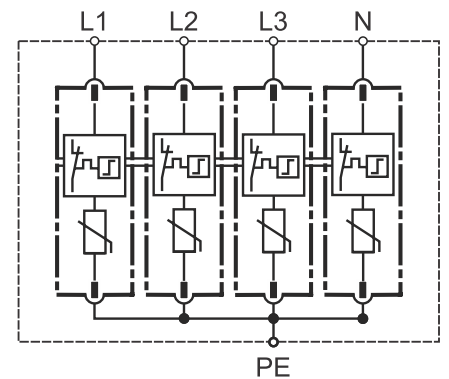

Connection Diagram



SPPV3T2-1000

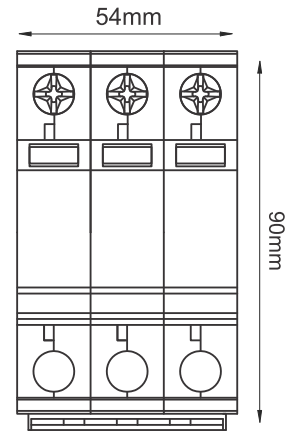

Product Dimension

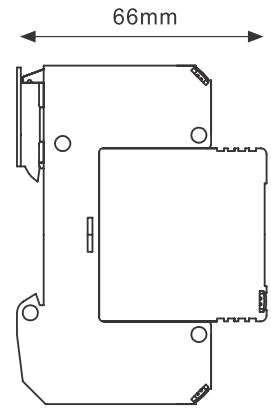

Product Dimension

TECHNICAL PARAMETERS	SPECIFICATIONS
SPD Classification According to EN61643-31	Type 2
SPD Classification According to IEC61643-31	Class II
Max. Continuous Operating Voltage (U_{cpv})	1000V DC
Nominal Discharge Current (I_n)	20kA
Max. Discharge Current (I_{max})	40kA
Voltage Protection Level (U_p)	$\leq 4.0kV$
Response Time (t_A)	$\leq 25ns$
Operating Temperature Range (T_u)	$-40^{\circ}C$ to $+70^{\circ}C$
Operating State / Fault Indication	Green / Red
Cross-Section Area (Min)	$4mm^2$
Cross-Section Area (Max)	$25mm^2$
Mounting	35mm Din rail
Enclosure Material	Thermoplastic UL94-V0
Short Circuit Current Rating (I_{scpv})	1000A
Remote Signalling Contact	Optional
Degree of Protection	IP20

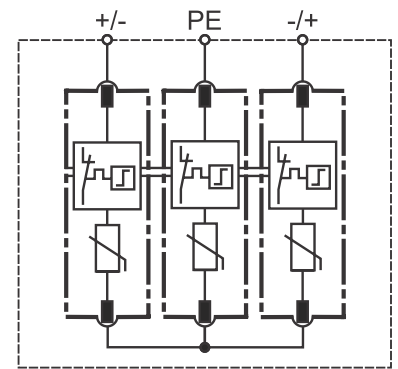

Connection Diagram



'elmex' 1000V DC with Remote Signalling Contact - Type 2 SPD



SPPV3T2-1000R

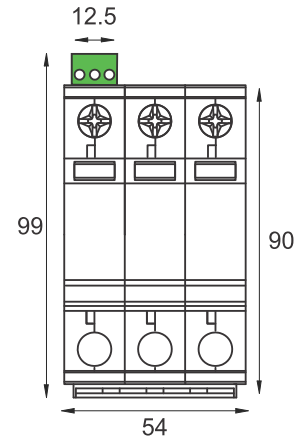

Product Dimension

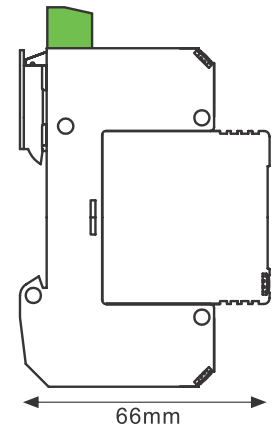

Product Dimension

TECHNICAL PARAMETERS	SPECIFICATIONS
SPD Classification According to EN61643-31	Type 2
SPD Classification According to IEC61643-31	Class II
Max. Continuous Operating Voltage (U_{cpv})	1000V DC
Nominal Discharge Current (I_n)	20kA
Max. Discharge Current (I_{max})	40kA
Voltage Protection Level (U_p)	$\leq 4.0kV$
Response Time (t_a)	$\leq 25ns$
Operating Temperature Range (T_u)	$-40^{\circ}C$ to $+70^{\circ}C$
Operating State / Fault Indication	Green / Red
Cross-Section Area (Min)	$4mm^2$
Cross-Section Area (Max)	$25mm^2$
Mounting	35mm Din rail
Enclosure Material	Thermoplastic UL94-V0
Short Circuit Current Rating (I_{scpv})	1000A
Remote Signalling Contact	Yes
Degree of Protection	IP20

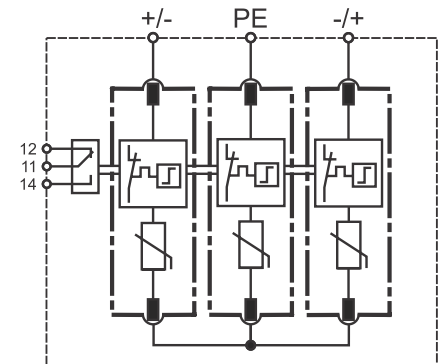

Connection Diagram



SPPV3T2-1500

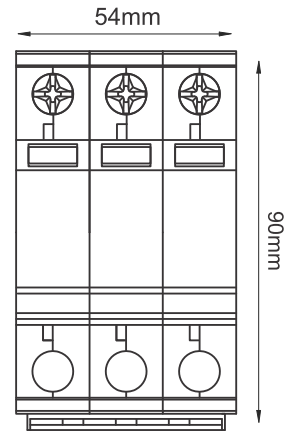

Product Dimension

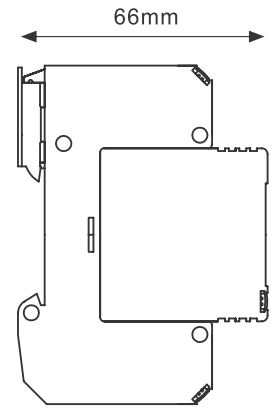

Product Dimension

TECHNICAL PARAMETERS	SPECIFICATIONS
SPD Classification According to EN61643-31	Type 2
SPD Classification According to IEC61643-31	Class II
Max. Continuous Operating Voltage (U_{cpv})	1500V DC
Nominal Discharge Current (I_n)	20kA
Max. Discharge Current (I_{max})	40kA
Voltage Protection Level (U_p)	$\leq 5.2kV$
Response Time (t_a)	$\leq 25ns$
Operating Temperature Range (T_u)	$-40^{\circ}C$ to $+70^{\circ}C$
Operating State / Fault Indication	Green / Red
Cross-Section Area (Min)	$4mm^2$
Cross-Section Area (Max)	$25mm^2$
Mounting	35mm Din rail
Enclosure Material	Thermoplastic UL94-V0
Short Circuit Current Rating (I_{scpv})	1000A
Remote Signalling Contact	Optional
Degree of Protection	IP20

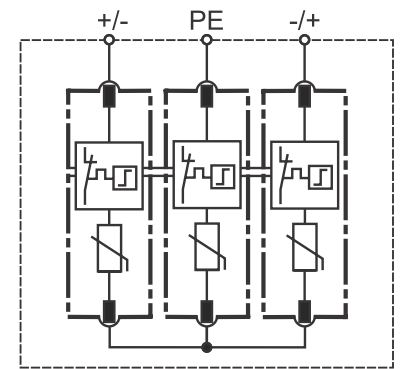

Connection Diagram



'elmex' 1500V DC with Remote Signalling Contact - Type 2 SPD



SPPV3T2-1500R

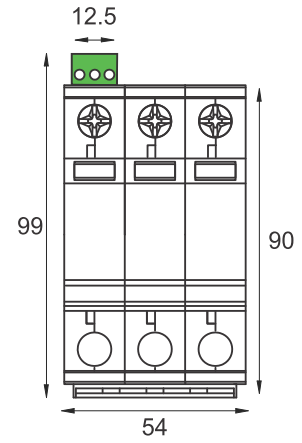

Product Dimension

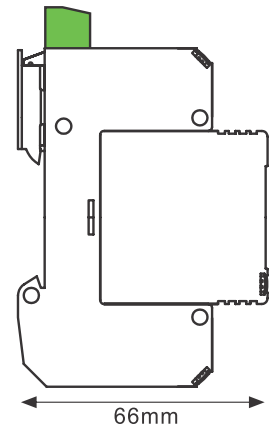

Product Dimension

TECHNICAL PARAMETERS	SPECIFICATIONS
SPD Classification According to EN61643-31	Type 2
SPD Classification According to IEC61643-31	Class II
Max. Continuous Operating Voltage (U_{cpv})	1500V DC
Nominal Discharge Current (I_n)	20kA
Max. Discharge Current (I_{max})	40kA
Voltage Protection Level (U_p)	≤ 5.2 kV
Response Time (t_A)	≤ 25 ns
Operating Temperature Range (T_u)	-40°C to $+70^\circ\text{C}$
Operating State / Fault Indication	Green / Red
Cross-Section Area (Min)	4mm^2
Cross-Section Area (Max)	25mm^2
Mounting	35mm Din rail
Enclosure Material	Thermoplastic UL94-V0
Short Circuit Current Rating (I_{scpv})	1000A
Remote Signalling Contact	Yes
Degree of Protection	IP20

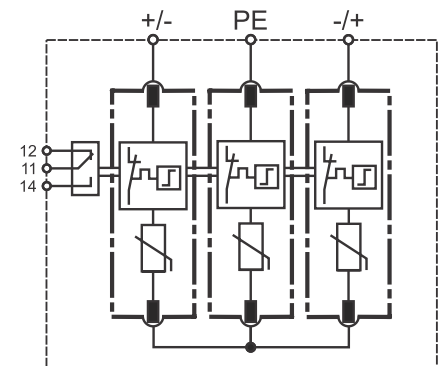

Connection Diagram



SPPV2T2-600

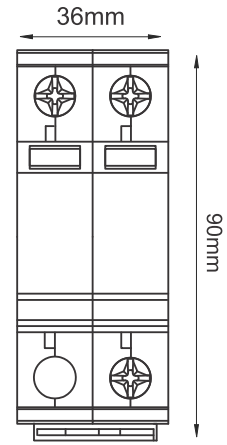

Product Dimension

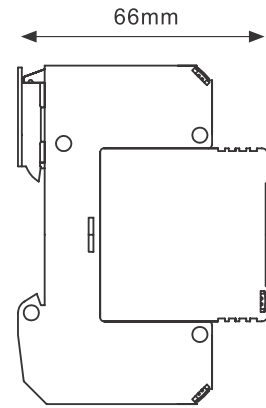

Product Dimension

TECHNICAL PARAMETERS	SPECIFICATIONS
SPD Classification According to EN61643-31	Type 2
SPD Classification According to IEC61643-31	Class II
Max. Continuous Operating Voltage (U_{cpv})	600V DC
Nominal Discharge Current (I_n)	20kA
Max. Discharge Current (I_{max})	40kA
Voltage Protection Level (U_p)	$\leq 2.8kV$
Response Time (t_A)	$\leq 25ns$
Operating Temperature Range (T_u)	$-40^{\circ}C$ to $+70^{\circ}C$
Operating state / fault indication	Green / Red
Cross-Section Area (Min)	$4mm^2$
Cross-Section Area (Max)	$25mm^2$
Mounting	35mm Din rail
Enclosure Material	Thermoplastic UL94-V0
Short Circuit Current Rating (I_{scpv})	1000A
Remote Signalling Contact	Optional
Degree of Protection	IP20

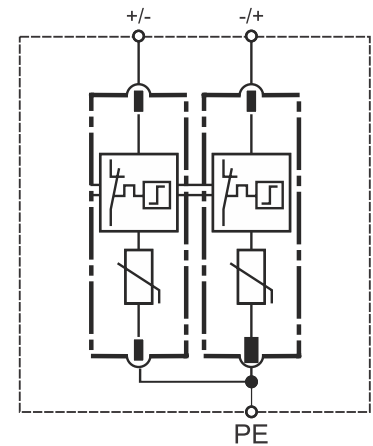

Connection Diagram



PV Straight Connector



EMPV4N

PV Panel Connector



EMPVPCM4N

EMPVPCF4N

PV Branch Connector



EBPV4F-N

EBPV4M-N

PV In-line Fuse Connectors



EMPV4IFC

EMPV4IFCM

EMPV4IFCF

PV Solar Customized Wire Harnesses Solution



'Y - Type' Wire Harness

4 - Rail PV Junction Box



EPVJB-F

PV Fuse Terminal Block & PV Fuse Link



EPVFH1000NV

EPVFH1500NV

Terminal Blocks for PV Applications



Screw Clamp Terminal Blocks



Screwless Terminal Blocks



Elmex Controls Pvt. Ltd. | Elmex Electric Pvt. Ltd.

12, GIDC Estate, Makarpura, Vadodara -390010, Gujarat, India

☎ 0265-2642021 / 23

✉ marketing@elmex.net

🌐 www.elmex.net



Scan for Website



ElmexControls



ElmexControls



ElmexControls



ElmexControls



ElmexControls

